

Suspended Cubicle Curtain Track



MATERIAL	#6063 Extruded Aluminum
FINISH	Satin Anodized or White Powder Coat
BENDS	All bends shall be 12" radius and up to 90 degrees
CARRIERS	ROLLER 12 - Nylon axle, two nylon wheels, tangle free nylon swivel, and nickel plated steel hook.

SUSPENDED 1100CT

1109 Coupling Sleeve Left Hand Shown (CSL)

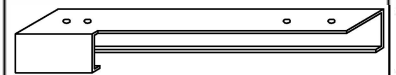

1107 End Cap (EC)

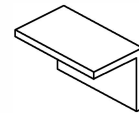

1108 Connector (C)

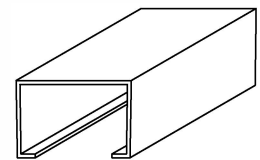

1115 Wall Bracket (WB)

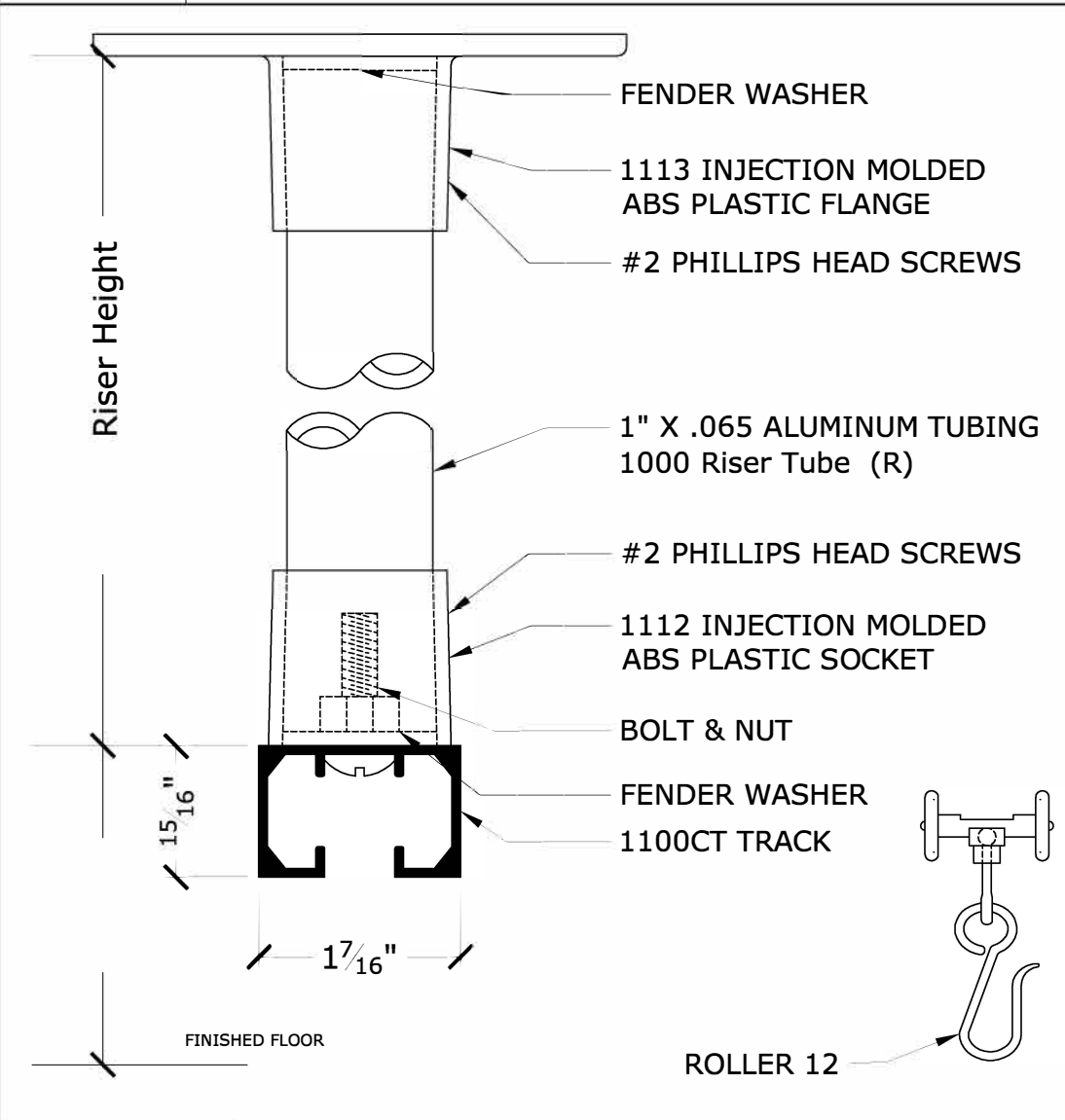
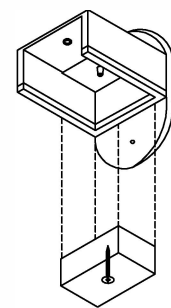

ARCHITECT	
CONTRACTOR	
DISTRIBUTOR	
PROJECT	

DATE	
DATE REV	
DRAWN BY	
JOB #	
SHEET	

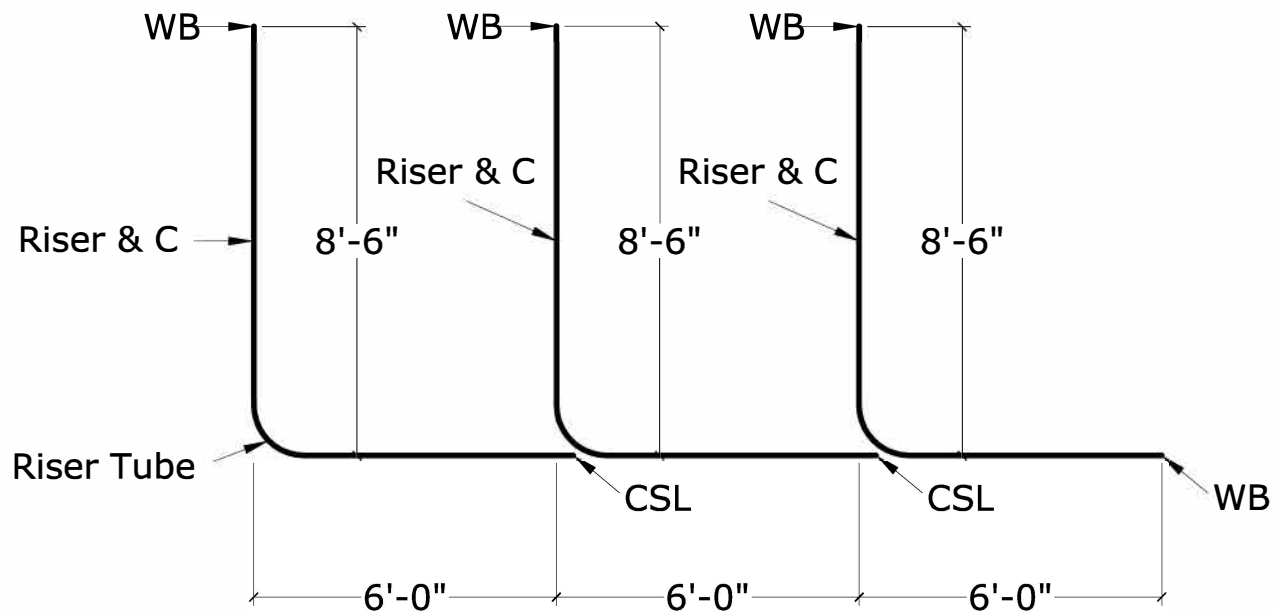

TYPICAL SUSPENDED TRACK PARTS:

- 1107 End Cap:** Aluminum End Cap is used as a permanent stop for curtain carriers. It is secured to the track with one (1) rivet.
- 1108 Connector:** Aluminum connector is used to join two pieces of track. It is secured with four (4) rivets, two per track piece.
- 1115 Wall Bracket:** Plastic Wall Bracket provides a removable cap for easy addition and removal of curtain carriers. It is secured to the track with one (1) rivet. It also allows the end of a track piece to be fastened to the wall (screws not provided).
- 1109 Coupling Sleeve:** Aluminum Coupling Sleeve is used to attach the end of a straight piece of track to an adjoining track (with a radius). It adds rigidity to both track layouts and eliminates the need for a riser tube. It is 12" long and is secured with four (4) rivets, two per track piece. Coupling sleeves are available as right and left hand.
- 1112 Socket:** ABS plastic socket attaches to the track with (1) bolt, nut, and washer. Riser tube is inserted and secured to the socket with (2) screws.
- 1113 Flange:** ABS plastic flange attaches to the ceiling with a screw or bolt (not provided). Riser tube is inserted and secured to the flange with (2) screws.
- 1000 Riser Tube:** Aluminum riser tube "suspends" the track from the ceiling. It may be cut to length and must be spaced no more than 84" O.C. Riser tubes should be placed at each connector and tangent to each 90° bend.